

Schutzvermerk nach DIN 34 beachten

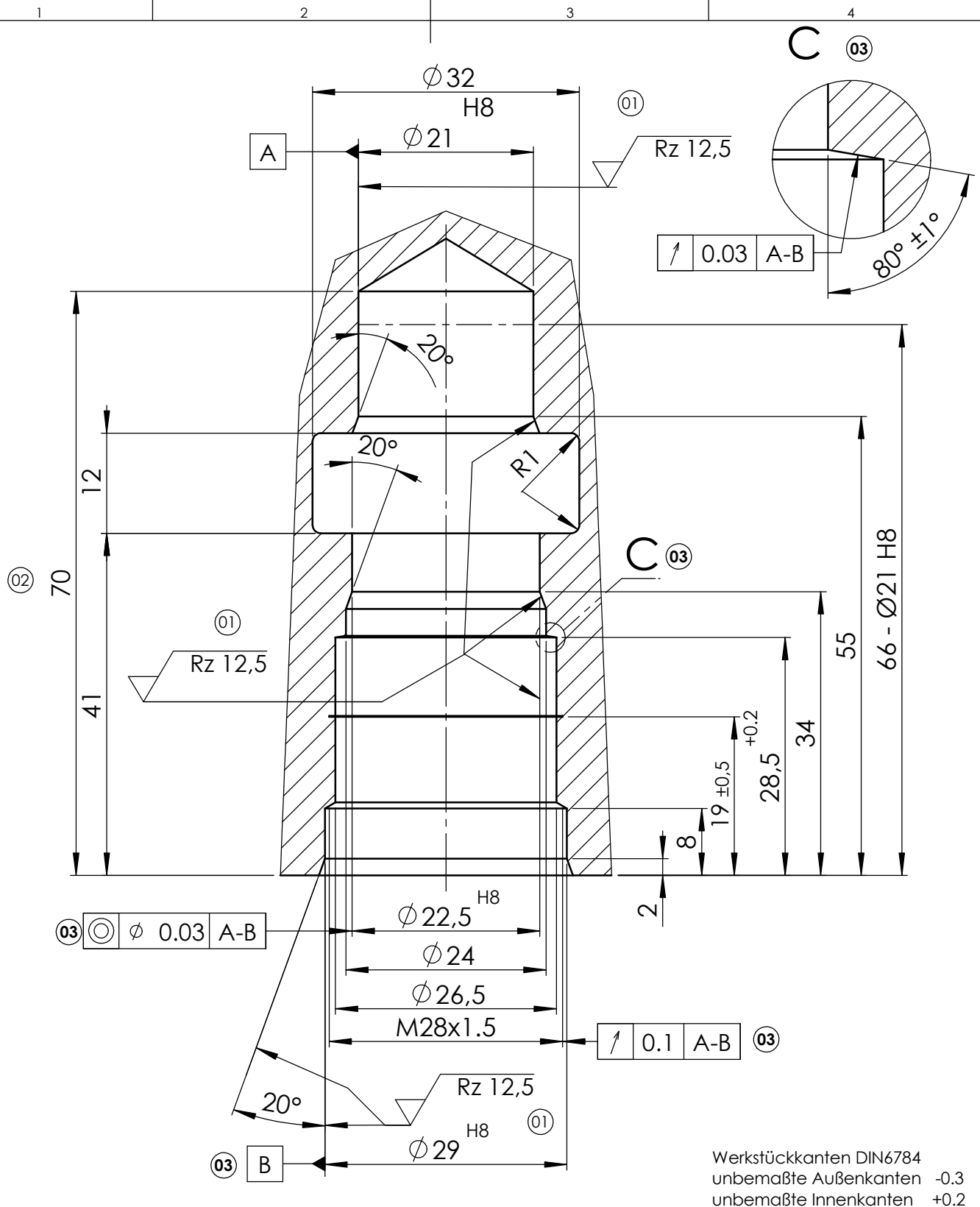

		03 07.12.21	21.286.00	dörk	wiesner/dörk	GEÄNDERT: Alle Form- u. Lagetoleranzen und Bezüge. HINZU: Detail C.		
29 H8	+0.033 0	Index/Datum	Änd.-Nr.	Bearbeitet	Geprüft	Änderung		
22.5 H8	+0.033 0	Oberfl.- Angabe DIN ISO 1302	Allgemein- toleranzen ISO 2768 MITTEL	QS-Freigabe	Oberflächen- schutz	Darstellung Methode E	Maßstab 1.5:1	Werkstoff
21 H8	+0.033 0							
Passung	Abmaße	Bearb.	09.11.04	wiedenmann	Benennung STUFENBOHRUNG WESSEL-PATRONE			
		Gepr.	11/04	van büren				
		Norm	11/04	wiesner	Identnr. 8.00051			
		Urspr.						
03	21.286.00	AE-1-4			Projektr.		Datenbanknr. 28365	
02	009/12	C1						
01	148/10	A3,C2,E2						
Index	Änd.-Nr.	Feld					Blatt Bl.	

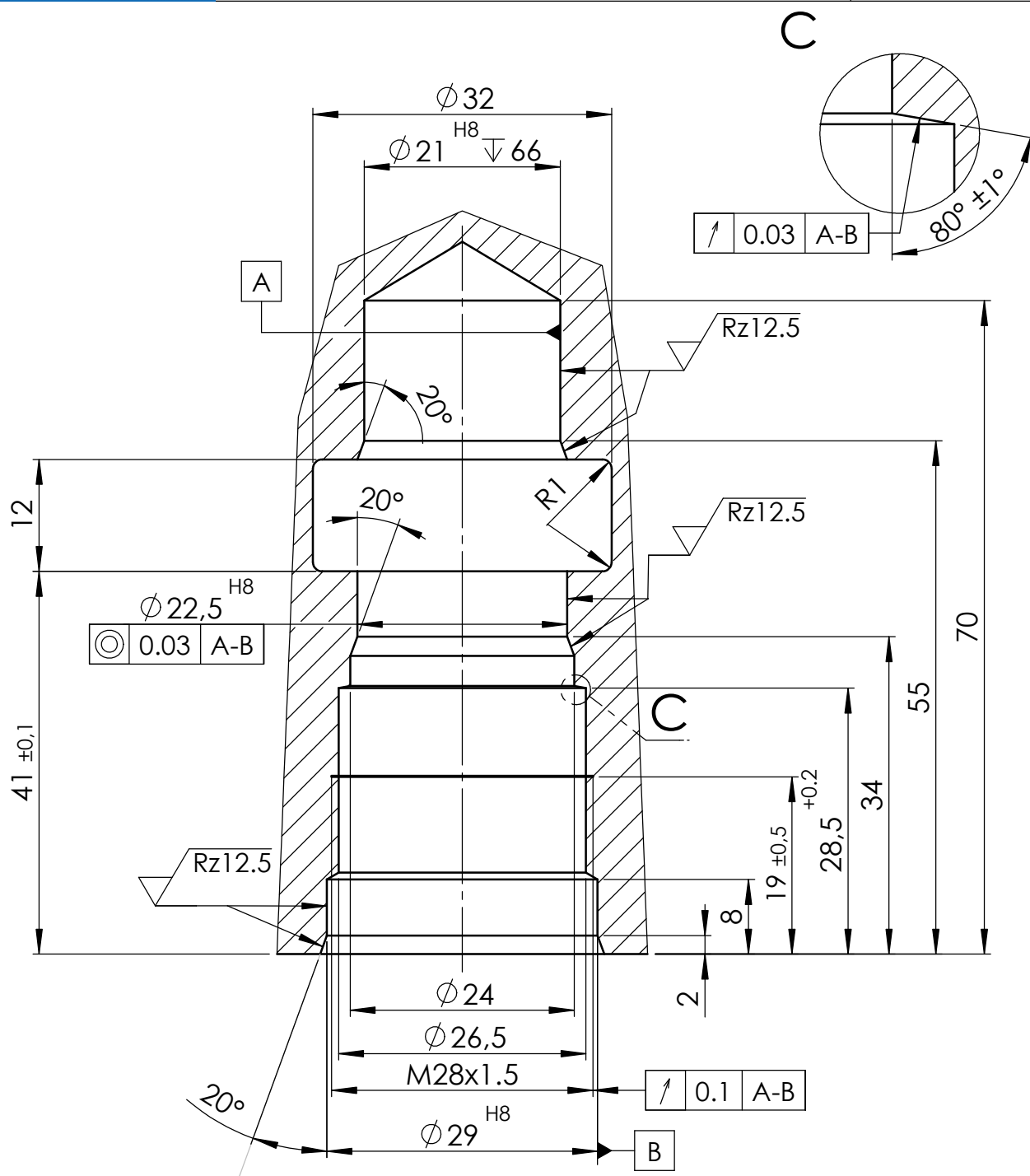

we engineer your progress

29 H8	+0.033 0
22.5 H8	+0.033 0
21 H8	+0.033 0
fitting	diameter

Bore diameter after fitting
max. 0.5 mm smaller.

Dimensions in millimeters

workpiece edge DIN 6784
undimensioned workpiece edge -0.3
undimensioned inner edge +0.2

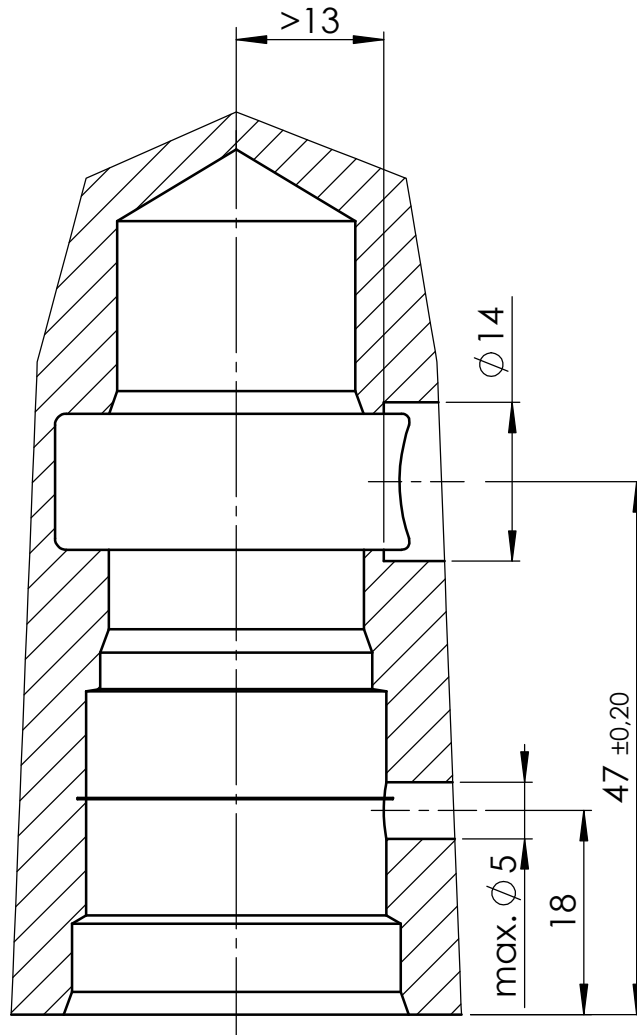

we engineer your progress

Dimensions in millimeters

workpiece edge DIN 6784

undimensioned workpiece edge -0.3

undimensioned inner edge $+0.2$

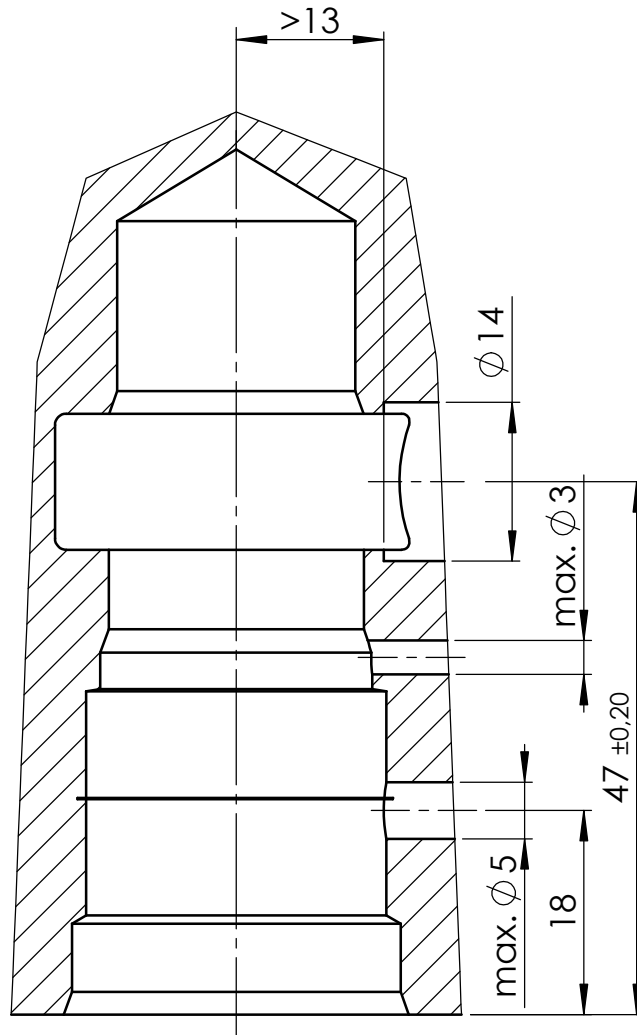

we engineer your progress

Dimensions in millimeters

workpiece edge DIN 6784

undimensioned workpiece edge -0.3

undimensioned inner edge $+0.2$