

we engineer your progress

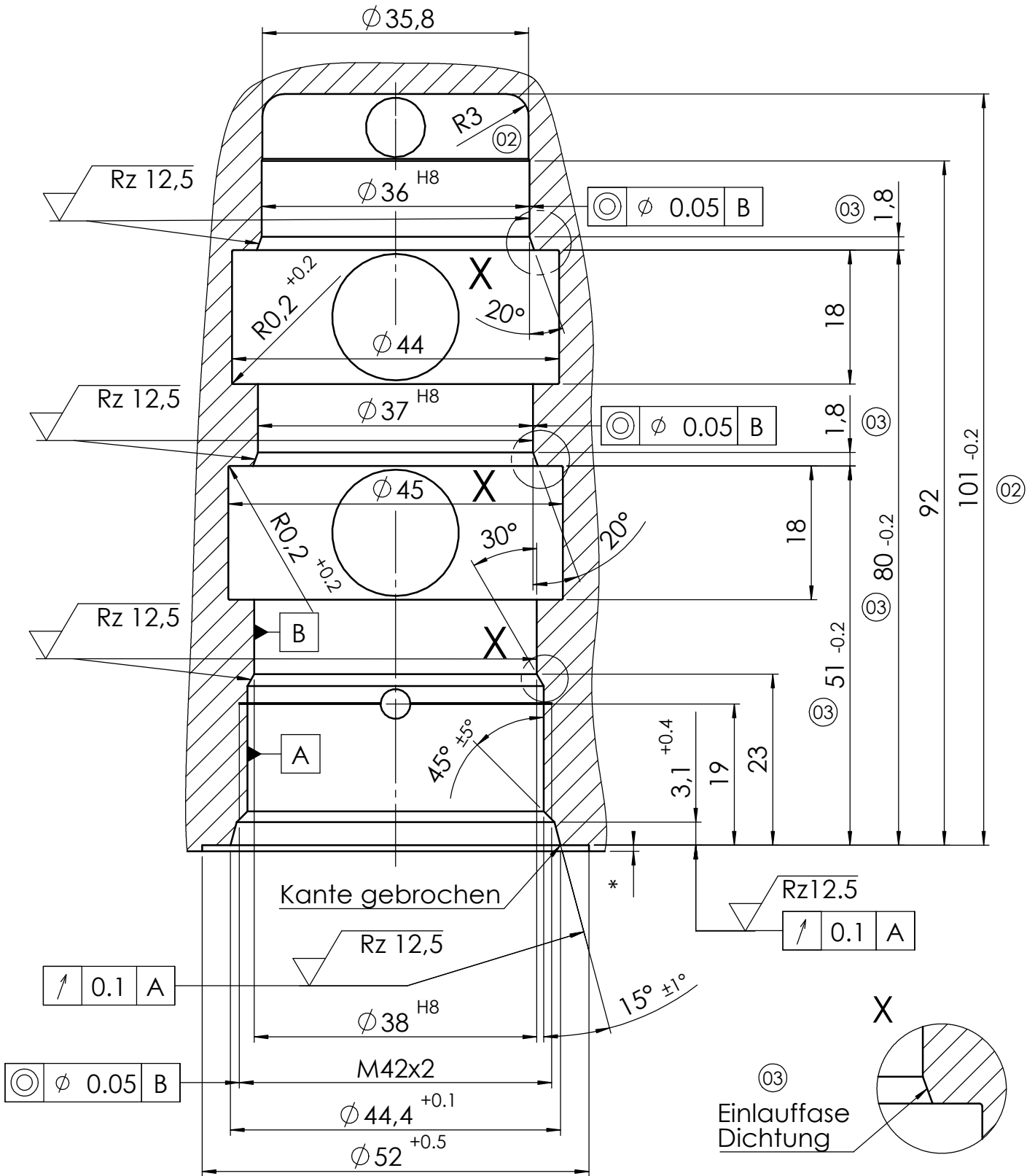

Bore diameter after fitting max. 0.5 mm smaller.

Dimensions in millimeters

workpiece edge DIN 6784

undimensioned workpiece edge -0.3

undimensioned inner edge +0.2

38 H8	+0.039 0
37 H8	+0.039 0
36 H8	+0.039 0
fitting	diameter

		13.04.11		01.06.2021		10.007.0240.9		index		03
heyn	prepared on	changed on	Project-no.	page	1	von	1			