

Bore diameter after fitting  
max. 0.5 mm smaller.

Dimensions in millimeters

workpiece edge DIN 6784

undimensioned workpiece edge -0.3

undimensioned inner edge +0.2

we engineer your progress

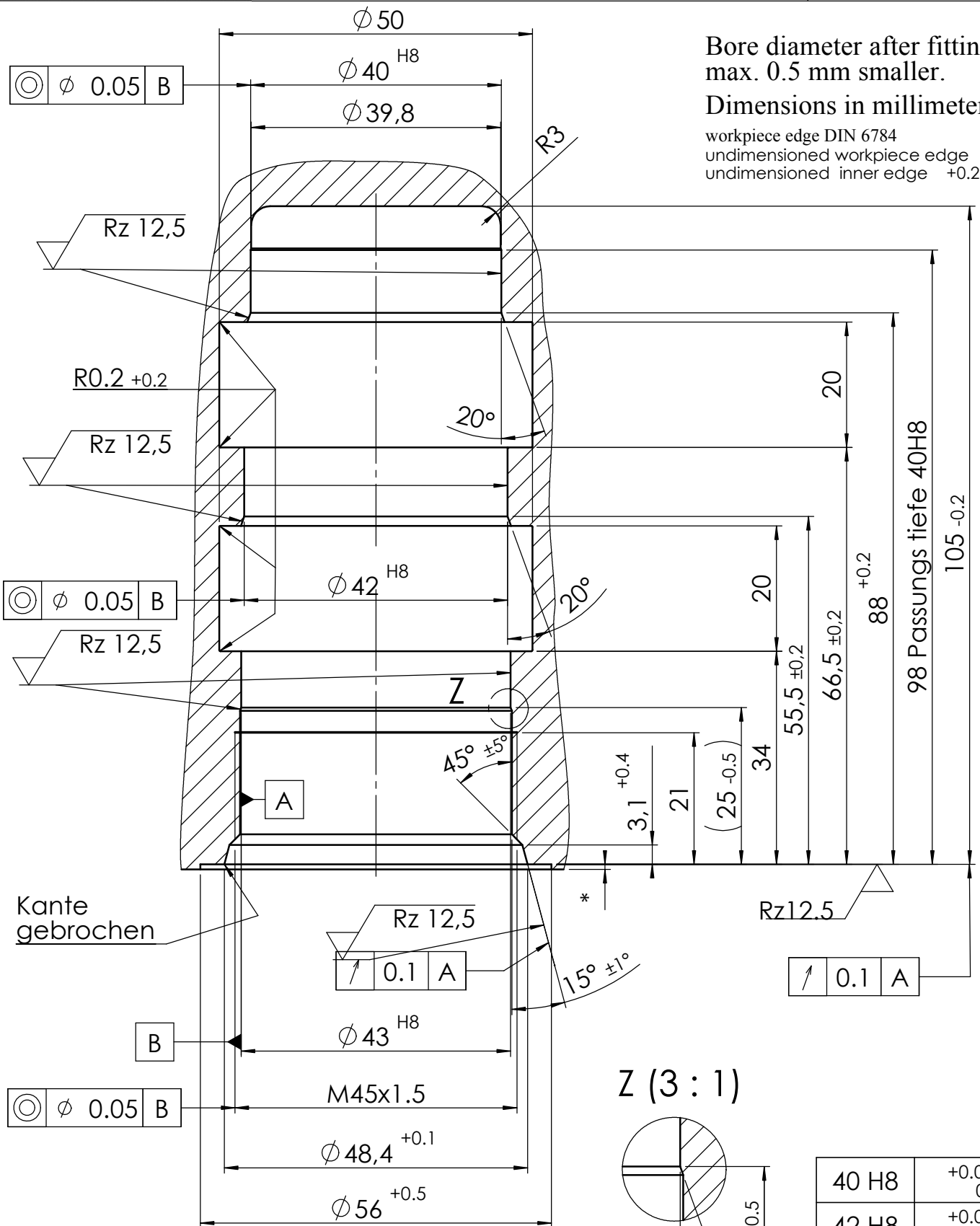

Kante gebrochen

B

0.05 B

0.05 B

0.05 B

0.05 B

0.05 B

0.05 B

40 H8	+0.039 0
42 H8	+0.039 0
43 H8	+0.039 0
fitting diameter	

Index / Datum	Änd. Nr.	Bearbeitet	Geprüft	Änderung
heyen	prepared on	13.02.18	changed on	22.10.2018
ID-Nr.8.00258		index: 01	page	1 von 1