

## Table of Content

<b>1</b>	<b>Product Details</b> .....	<b>2</b>
1.1	Application .....	2
1.2	Recommended Installation.....	2
<b>2</b>	<b>Function</b> .....	<b>2</b>
2.1	Features .....	2
<b>3</b>	<b>Technical Data</b> .....	<b>3</b>
<b>4</b>	<b>Ordering Informationen</b> .....	<b>3</b>
4.1	Currently available versions of the section assemblies .....	3
<b>5</b>	<b>Modules</b> .....	<b>4</b>
5.1	Inlet sections .....	4
5.1.1	Inlet section as flange with LS-amplifier .....	4
5.1.2	Inlet section as an intermediate plate with LS-amplifier and priority function .....	4
5.2	Working sectors .....	4
5.2.1	4/3, NG-10, without pressure compensator .....	4
5.2.2	4/3 NG-10, with pressure compensator .....	4
5.2.3	4/2 NG-10, with pressure compensator .....	5
5.2.4	4/3 NG-6, unlockable check valves in A / B, 60 l / min .....	5
5.2.5	4/2 NG-6, 2/2 way poppet valve B, A closed .....	5
5.2.6	4/3 NG-6, 2/2 way valve in A / B, pressure relief valve in A, 20 l / min .....	5
5.2.7	4/3 NG-6, counterbalance valves in A / B, pressure relief valves in A / B, 60 l / min .....	5
5.2.8	4/3 NG-6, lowering valve and pressure relief valve in A, pilot operated check valve in B, 60 l / min .....	6
5.2.9	4/3 NG-6, counterbalance valves in A / B, 10 l / min .....	6
5.2.10	4/3 NG-6, pilot operated check valve in A, 60 l / min .....	6
5.2.11	4/3, NG-10, pressure reducing valve A / B, 2/2 way valve in A, switching / proportional .....	6
5.2.12	Multiple block valves 4/3 NG 6 2/2 way poppet valves in C / D .....	7
5.2.13	Flow Sensors .....	7
5.2.14	Intermediate fixing plate .....	7
5.2.15	Termination left .....	7
5.2.16	Termination right .....	7
<b>6</b>	<b>Installation</b> .....	<b>8</b>
6.1	General Information .....	8
<b>7</b>	<b>Notes, standards and safety requirements</b> .....	<b>8</b>
7.1	General Information .....	8
7.2	Standards .....	8
<b>8</b>	<b>Accessories</b> .....	<b>8</b>

## 1 Product Details

The main control valve MCV-LC can operate electrically switched or proportional different consumers, as cylinders and rotary actuators. Additional components as lock valves load holding valves or pressure valves can be integrated. WESSEL MCV-LC is characterized by a compact design with high efficiency and variable design.

### 1.1 Application

The directional valve MCV-LC can be used as a main control valve to extend the functionality in mobile machines. By connecting it to the existing hydraulic system extra work functions can easily be integrated into the machine.

### 1.2 Recommended Installation

The additional section can be installed at any position or close to the additional consumer.

## 2 Function

The main control valve is designed as a load-sensing control block. The highest load pressure signal is applied to the pump control port. In idle state, the signal will be relieved to the tank so that the pump is not displaced. An LS-amplifier ensures a strong LS-signal even for extra long signal lines. Directional control valve sections supply single or double acting consumers. When operating with a fixed displacement pump, the pump flow can be switched to bypass when no flow is required. Special consumers such as the steering function can be supplied with priority by means of a 2- or 3-way flow controller.

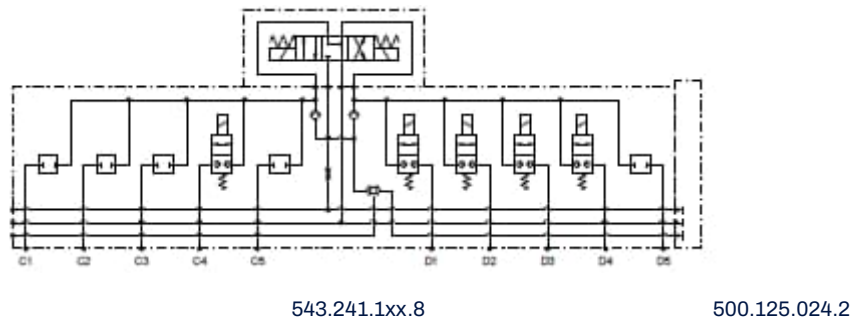
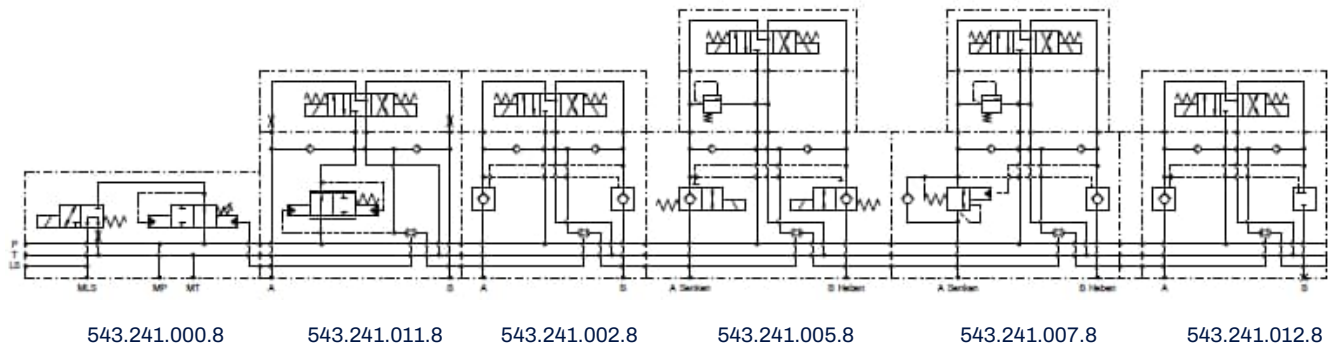

### 2.1 Features

- Modular design for one- and two-way consumers NG10, NG 6 Flow range 10 l / min - 90 l / min
- Variability of consumer
- All functions electrically switching, optionally proportional
- Suitable for LS- and fixed displacement pump systems
- Integrated valve technology such as lock valves, load holding valves, pressure relief valves, flow control valves, etc.
- input flow rate up to 150 l / min

## 3 Technical Data

Criterion	Unit	Value
mounting position		any
Maximum inlet pressure	bar	240
Adjustable pressure at the consumer	bar	is set at the respective work section
Factory set outlet volume flow	l/min	is set at the respective work section
Accuracy of the output flow rate	%	± 4
Maximum recommended tank pressure (T)	bar	< 1
Maximum input flow rate (P)	l/min	150
Minimum input flow rate (P)		~ 20% above the adjusted output flow
Hydraulic fluid		Mineral oil (HLP, HLP) to DIN 51524, other fluids on request
Hydraulic fluid temperature range	°C	-20 to +80
Ambient temperature	°C	< +50
Viscosity range	mm <sup>2</sup> /s	2,8 - 500
Contamination		Filtration to NAS 1638, class 9, with minimum retention rate β10≥75
Supply voltage	VDC	12 or 24
Voltage tolerance	%	± 10
Power consumption solenoid	W	33
Current consumption solenoid	A	2.9 at 12VDC, 1,4 at 24VDC
Duty solenoid	%	100
Protection according to DIN 40050		IP 65
Power supply plug		Angle plug ISO 4400 or AMP Junior Timer plug

## 4 Ordering Informationen

### 4.1 Currently available versions of the section assemblies

Type	Part No.	Designation
000.8	543.241.000.8	Inlet section as end plate with LS-signal amplifier, P = G3 / 4 , t = G1, LS, MP, MLS, MT = G1 / 4
014.8	543.241.014.8	Inlet section as an intermediate plate with priority, LS signal amplifier, P = G3/4 , t = G1, LS, MP, MLS, MT = G1/4
026.8	543.241.026.8	4/3, NG-10, 12V, without pressure compensator
021.8	543.241.021.8	4/3, NG-10, 12V, pressure compensator, 45 l/min in A/B
011.8	543.241.011.8	4/3, NG-10, 12V, pressure compensator, 50 l/min in A/B
001.8	543.241.001.8	4/3, NG-10, 12V, pressure compensator, 60 l/min in A/B
010.8	543.241.010.8	4/3, NG-10, 12V, pressure compensator, 90 l/min in A/B
031.8	543.241.031.8	4/3, NG-10, 12V, pressure compensator A= 0 l/min, B= 75 l/min
022.8	543.241.022.8	4/3, NG-10, 12V, pressure compensator A= 45 l/min, B= 60 l/min
030.8	543.241.030.8	4/3, NG-10, 12V, pressure compensator A= 60 l/min, B= 75 l/min
002.8	543.241.002.8	4/3, NG-6, 12V, unlockable check valves in A / B, 60 l / min
005.8	543.241.005.8	4/3, NG-6, 12V, 2/2 in A/B, pressure relief valve in A, 30 l / min
009.8	543.241.009.8	4/3, NG-6, 12V, lowering brake valve in A / B, pressure relief valve in A / B, 10 l / min
007.8	543.241.007.8	4/3, NG-6, 12V, lowering brake valve and pressure relief valve in A, unlockable check valves in B, A = 10 l / min, B = 60 l / min
008.8	543.241.008.8	4/3, NG-6, 12V, lowering Brake valve in A / B, 10 l / min
012.8	543.241.012.8	4/3, NG-6, 12V, unlockable check valve in A, A = 60 l / min
006.8	543.241.006.8	4/2, NG-6, 12V, S2 / 2 in B, 30 l / min, A locked
023.8	543.241.023.8	4/2, NG-10, 12V, pressure compensator, 45 l/min in B
003.8	543.241.003.8	4/2, NG-10, 12V, pressure compensator, 75 l/min in B
024.8	543.241.024.8	4/2, NG-10, 12V, pressure compensator, 90 l/min in B
015.8	543.241.015.8	4/3, NG-10, 12V, pressure reducing valve with 2/2 (switch) in P, 2/2 leakage free in A
016.8	543.241.016.8	4/3, NG-10, 12V, pressure reducing valve with 2/2 (proportional) in P 2/2 leakage free in A
025.8	543.241.025.8	flow Sensors
1XX.8	543.241.1XX.8	4/3, NG-6, 12V, multi-block, C / D = 19 l / min
022.2	500.125.022.2	end plate, left
023.2	500.125.023.2	intermediate fixing plate
024.2	500.125.024.2	end plate, right

## 5 Modules

### 5.1 Inlet sections

#### 5.1.1 Inlet section as flange with LS-amplifier

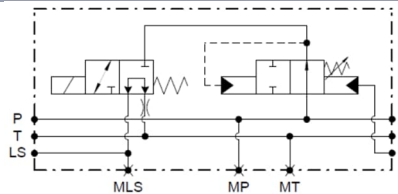
Specification	Parameter	Schematic
<p>The inlet section is equipped with an LS signal amplifier. The pressure amplification is adjustable. In idle condition the LS signal is routed to the tank.</p> <p>Part number: 543.241.000.8</p> 	<p>P G3/4" T G1" LS G1/4" Q<sub>max</sub> = 150 l/min P<sub>max</sub> an P, LS = 240 bar P<sub>max</sub> an T &lt; 20 bar</p> <p>Electrical: 12V DC</p>	

#### 5.1.2 Inlet section as an intermediate plate with LS-amplifier and priority function

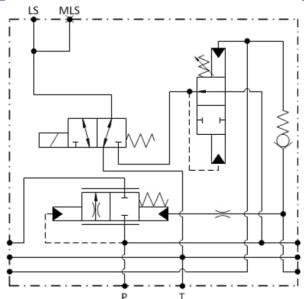
Specification	Parameter	Schematic
<p>This inlet section is designed as an intermediate plate with priority function and LS-amplifier. A pressure compensator in the inlet ensures priority supply on the right side. In idle condition the LS signal is routed to the tank.</p> <p>Part number: 543.241.014.8</p> 	<p>P G3/4" T G1" LS, MLS G1/4"</p> <p>Q<sub>max</sub> = 170 l/min P<sub>max</sub> an P, LS = 240 bar P<sub>max</sub> an T &lt; 20 bar</p> <p>Electrical: 12V DC</p>	

### 5.2 Working sectors

#### 5.2.1 4/3, NG-10, without pressure compensator

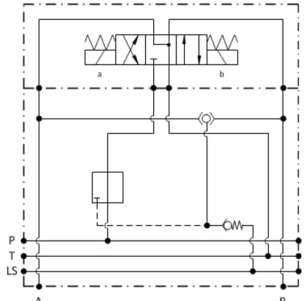
Specification	Parameter	Schematic
<p>This work section offers a 4/3 directional valve function in which the ports A and B can either be connected to the pump or connected to the tank.</p> <p>Part number: 543.241.026.8:</p> 	<p>A, B = G3/4 ISO 1179-1 Q<sub>max</sub> = 90 l/min P<sub>max</sub> an A, B, P, LS = 240 bar P<sub>max</sub> an T &lt; 20 bar</p> <p>Electrical: 12V DC</p>	

#### 5.2.2 4/3 NG-10, with pressure compensator

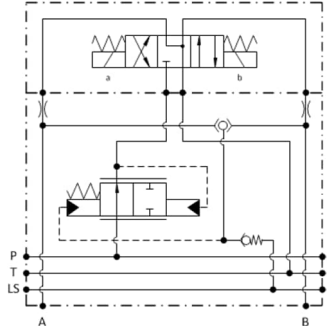
Specification	Parameter	Schematic
<p>This work section is equipped with an inlet pressure compensator. Upon actuation of the valve, the flow is passed through a fixed orifice, where-by the flow is regulated to the consumer at a certain value (2-way flow control).</p> <p>Part number: 543.241.021.8: 45 l/min Part number: 543.241.011.8: 50 l/min Part number: 543.241.001.8: 60 l/min Part number: 543.241.010.8: 90 l/min</p> <p>Part number: 543.241.031.8: A=0 l/min, B=75 l/min</p> <p>Part number: 543.241.022.8: A=45 l/min, B=60 l/min</p> <p>Part number: 543.241.030.8: A=60 l/min, B=75 l/min</p> 	<p>A, B = G3/4 ISO 1179-1 Q<sub>max</sub> an A, B = siehe links P<sub>max</sub> an A, B, P, LS = 240 bar P<sub>max</sub> an T &lt; 20 bar</p> <p>Electrical: 12V DC</p>	

## 5.2.3 4/2 NG-10, with pressure compensator

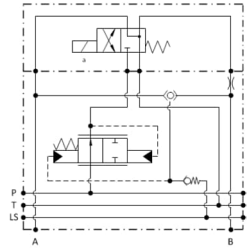
Specification	Parameter	Schematic
<p>This work section is equipped with an inlet pressure compensator. The valve is designed as 4/2 directional valve, a flow control function is provided only for one direction (B).</p> <p>Part number: 543.241.023.8: 45 l/min Part number: 543.241.003.8: 75 l/min Part number: 543.241.024.8: 90 l/min</p> 	<p>A, B = G3/4 ISO 1179-1 Q<sub>max</sub> an B = siehe links P<sub>max</sub> an A, B, P, LS = 240 bar P<sub>max</sub> an T &lt; 20 bar</p> <p>Electrical: 12V DC</p>	

## 5.2.4 4/3 NG-6, unlockable check valves in A / B, 60 l / min

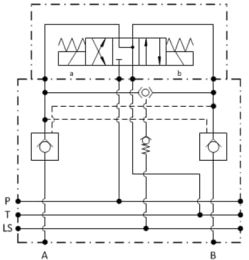
Specification	Parameter	Schematic
<p>With this work section it is possible to lock consumers leak-free. Therefore unlockable check valves are implemented in the directional control valve block.</p> <p>Part number: 543.241.002.8</p> 	<p>A, B = G3/4 ISO 1179-1 Q<sub>max</sub> an A, B = 60 l/min P<sub>max</sub> an A, B, P, LS = 240 bar P<sub>max</sub> an T &lt; 20 bar</p> <p>Electrical: 12V DC</p>	

## 5.2.5 4/2 NG-6, 2/2 way poppet valve B, A closed

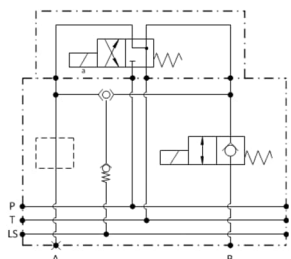
Specification	Parameter	Schematic
<p>This work section offers a 4/2 way valve function in which the port B is either connected to the pump or can be connected to the tank. In neutral position the consumer at port B is locked leak-free by means of an additional 2/2 directional valve. In order to lower the load only the 2/2 way valve has to be opened</p> <p>Part number: 543.241.006.8</p> 	<p>A, B = G3/4 ISO 1179-1 Q<sub>max</sub> an B = 30 l/min P<sub>max</sub> an B, P, LS = 240 bar P<sub>max</sub> an T &lt; 20 bar</p> <p>Electrical: 12V DC</p>	

## 5.2.6 4/3 NG-6, 2/2 way valve in A / B, pressure relief valve in A, 20 l / min

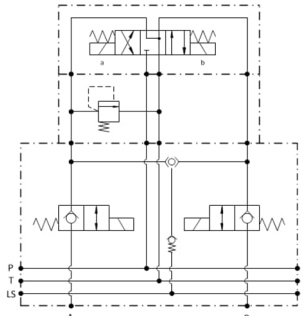
Specification	Parameter	Schematic
<p>This work section offers a 4/3 valve function. Both consumer ports are locked leak-free with a further 2/2 way valve. In order to lower the load only the 2/2 way valve has to be opened. In addition, there is a pressure relief valve in A.</p> <p>Part number: 543.241.005.8</p> 	<p>A, B = G3/4 ISO 1179-1 Q<sub>max</sub> an A, B = 30 l/min P<sub>max</sub> an A, B, P, LS = 240 bar P<sub>max</sub> an T &lt; 20 bar</p> <p>Electrical: 12V DC</p>	

## 5.2.7 4/3 NG-6, counterbalance valves in A / B, pressure relief valves in A / B, 60 l / min

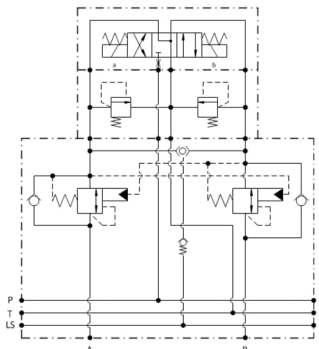
Specification	Parameter	Schematic
<p>This work section offers a 4/3 directional valve function. Both consumer ports are protected by pressure relief valves. Lowering brake valves ensure a safe and smooth operation.</p> <p>Part number: 543.241.009.8</p> 	<p>A, B = G3/4 ISO 1179-1 Q<sub>max</sub> an A, B = 10 l/min P<sub>max</sub> an A, B, P, LS = 240 bar P<sub>max</sub> an T &lt; 20 bar</p> <p>Electrical: 12V DC</p>	

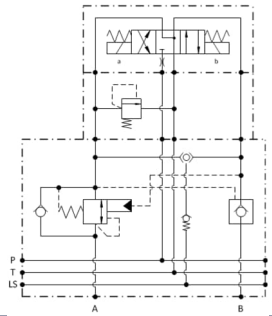

## 5.2.8 4/3 NG-6, lowering valve and pressure relief valve in A, pilot operated check valve in B, 60 l / min

Specification	Parameter	Schematic
<p>The working section offers a 4/3 directional valve function. The port A is protected by a pressure relief valve and provided with a lowering brake valve. The consumer port B is kept leak-free by means of an unlockable check valve.</p> <p>Part number: 543.241.007.8</p> 	<p>A, B = G3/4 ISO 1179-1  <math>Q_{\max}</math> an A = 10 l/min  <math>Q_{\max}</math> an B = 60 l/min  <math>P_{\max}</math> an A, B, P, LS = 240 bar  <math>P_{\max}</math> an T &lt; 20 bar</p> <p>Electrical: 12V DC</p>	

## 5.2.9 4/3 NG-6, counterbalance valves in A / B, 10 l / min

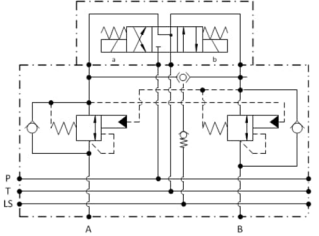
Specification	Parameter	Schematic
<p>This work section offers a 4/3 way valve function. Both consumer ports are equipped with lowering brake valves.</p> <p>Part number: 543.241.008.8</p> 	<p>A, B = G3/4 ISO 1179-1  <math>Q_{\max}</math> an A/B = 10 l/min  <math>P_{\max}</math> an A, B, P, LS = 240 bar  <math>P_{\max}</math> an T &lt; 20 bar</p> <p>Electrical: 12V DC</p>	

## 5.2.10 4/3 NG-6, pilot operated check valve in A, 60 l / min

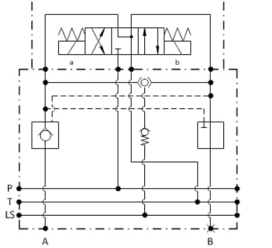
Specification	Parameter	Schematic
<p>With this work section it is possible to lock a consumer leak-free. Therefore an unlockable check valve is integrated into the main block between the directional valve and consumer port A. The consumer port B is closed.</p> <p>Part number: 543.241.012.8</p> 	<p>A, B = G3/4 ISO 1179-1  <math>Q_{\max}</math> = 60 l/min  <math>P_{\max}</math> an A, B, P, LS = 240 bar  <math>P_{\max}</math> an T &lt; 20 bar</p> <p>Electrical: 12V DC</p>	

## 5.2.11 4/3, NG-10, pressure reducing valve A / B, 2/2 way valve in A, switching / proportional

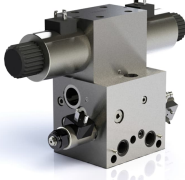
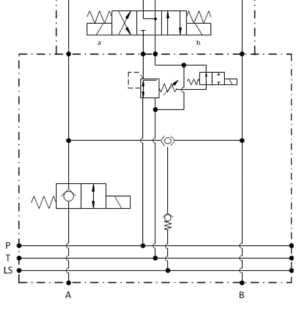
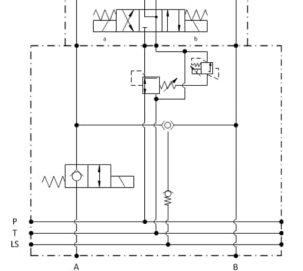
Specification	Parameter	Schematic
<p>This section is equipped with a pressure reducing valve in the inlet which is acting on A or B, depending on the switching position of the 4/3 directional valve. Connection A is locked leak-free by an additional 2/2 way valve, which can be opened for lowering. In the <b>switching</b> variant, the pressure reducing valve is controlled by supplying current to the 2/2 way valve and the full pump pressure can be used. The <b>proportional</b> version has an inverse proportional pressure relief valve which non energized activates the pressure reducing valve and and though enables the pump pressure to be used completely. By operating the proportional valve, the pressure reducing valve can be adjusted to the desired pressure.</p> <p>Part number: 543.241.015.8            - operation switching</p> <p>Part number: 543.241.016.8            - operation proportional</p> 	<p>A, B = G3/4 ISO 1179-1  <math>Q_{\max}</math> an A, B = 70 l/min  <math>P_{\max}</math> an A, B, P, LS = 240 bar  <math>P_{\max}</math> an T &lt; 20 bar</p> <p>Electrical: 12V DC</p>	<p>schaltend</p>  <p>proportional</p> 

## 5.2.12 Multiple block valves 4/3 NG 6 2/2 way poppet valves in C / D

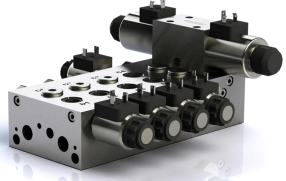
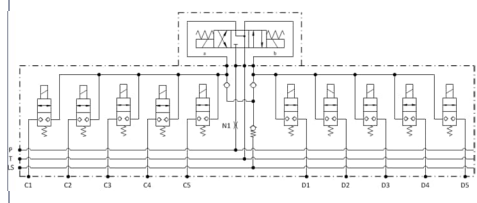
Specification	Parameter	Schematic
<p>In the multi-block a 4/3 valve is used to determine the direction. Leakage free 2/2 valves are used to decided which consumer is activated. The 2/2 seat valves can be installed variably up to 10 pieces.</p> <p>Part number: 543.241.1xx.8</p> 	<p>C1-C5, D1-D5 = G3/8  <math>Q_{\max}</math> an C, D = 19 l/min  <math>P_{\max}</math> an C, D, P, LS = 240bar  <math>P_{\max}</math> an T &lt; 20 bar</p> <p>Electrical: 12V DC</p>	

## 5.2.13 Flow Sensors

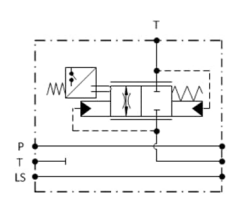
Specification	Parameter	Schematic
<p>The flow sensor detects a return flow to T. For an automated set-up, the switch can be used to select the end of a movement. The inductive sensor en-sures a wear-free operation.</p> <p>Part number: 543.241.025.8</p> 	<p>T = G3/4 nach ISO 1179-1  <math>Q_{\max}</math> = 100 l/min  <math>P_{\max}</math> an LS, P = 240 bar  <math>P_{\max}</math> an T &lt; 20 bar</p> <p>Electrical: 12V DC</p>	

## 5.2.14 Intermediate fixing plate

Specification	Image
<p>The intermediate fixing plate is re-quired for mounting the complete valve. The plate can be integrated at locations in the area of working sections where the valve should be fixed to a carrier.</p> <p>Part number: 500.125.023.2</p>	

## 5.2.15 Termination left

Specification	Image
<p>This section serves as an end plate of the entire main control valve. At the same time, this section can be used as fixing plate.</p> <p>Part number: 500.125.022.2</p>	

## 5.2.16 Termination right

Specification	Image
<p>This section serves as an end plate of the entire main control valve. At the same time, this section can be used as fixing plate.</p> <p>Part number: 500.125.024.1</p>	

## 6 Installation

### 6.1 General Information

- Observe installation and safety regulations of agricultural machine manufacturer
- Only technically permitted changes to the agricultural machine must be carried out
- The user must ensure that the device is suitable for its use.
- To be used solely for the purpose intended by the manufacturer.
- Before mounting / dismantling the hydraulic system must be depressurized.
- Can be set only by qualified personnel.
- Can only be opened with the permission of the manufacturer, otherwise the warranty will become void.

## 7 Notes, standards and safety requirements

### 7.1 General Information

- Als Dezimaltrenner in Zeichnungen wird das Komma ( , ) verwendet
- Alle Maße sind in mm angegeben

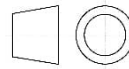

### 7.2 Standards

The following standards must be observed during the installation and operation of the valve:

- DIN EN ISO 13732-1: 2008-12, temperatures on exposed surfaces

## 8 Accessories

For particularly long main control valves, an additional strut profile is available. The strut profile allows a very flexible and easy installation and also protects the valve against torsional and bending stresses. Valve and strut profile are bolted together and mounted as one unit on the machine.

- strut profile part No. on request
- angle plug: part No. 340.201.900.6
- coil 24V: part No. 285.704.000.6
- coil 12V: part No. 285.703.000.6

