

## 1 Product Details



Pressure relief valves are used where a high pressure has to be reduced to a lower pressure level. By this a reduced pressure can be generated from a high pressure circuit in order to supply low pressure valves e.g. for piloting purposes.

### Characteristics

- Compact installation space
- Hardened valve components
- Wide adjustments range of 20 – 400 bar

## 2 Technical Data

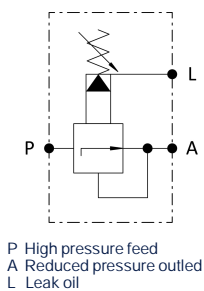

Max. operating pressure	bar	420
Maximum input pressure	bar	400
Max. volume flow	l/min	40
Weight	kg	0,4
Installation position		any
Tank pressure	bar	< 1 bar
Input volume flow	l/min	< 40 l/min
Hydraulic fluid		Mineral oil (HL, HLP) conforming with DIN 51524, other fluids upon request
Hydraulic fluid temperature range	°C	-25 bis +80
Ambient temperature:	°C	< +50
Viscosity range	mm <sup>2</sup> /s	2,8 - 500
Contamination grade		Filtering conforming with NAS 1638, class 9, with minimum retention rate β <sub>10</sub> ≥75

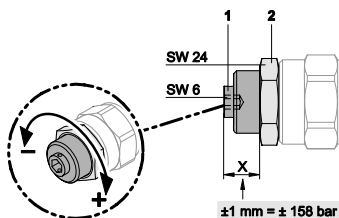

## 3 Setting the reduced pressure at port A

- Undo the counter-nut (2).
- Increasing output pressure: Turn the set-screw (1) to the right.
- Decrease output pressure: Turn the set-screw (1) to the left.
- Secure

## 4 Mounting

Das Druckminderventil wird in eine Stufenbohrung eingeschraubt.  
An SW 27 = Anzugsmoment 50 Nm.

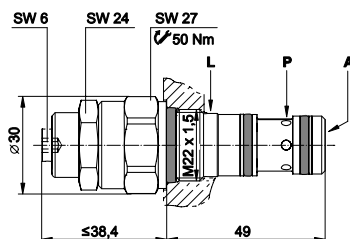

## 5 Stepped cavity NCS 06/03 – 8.00040

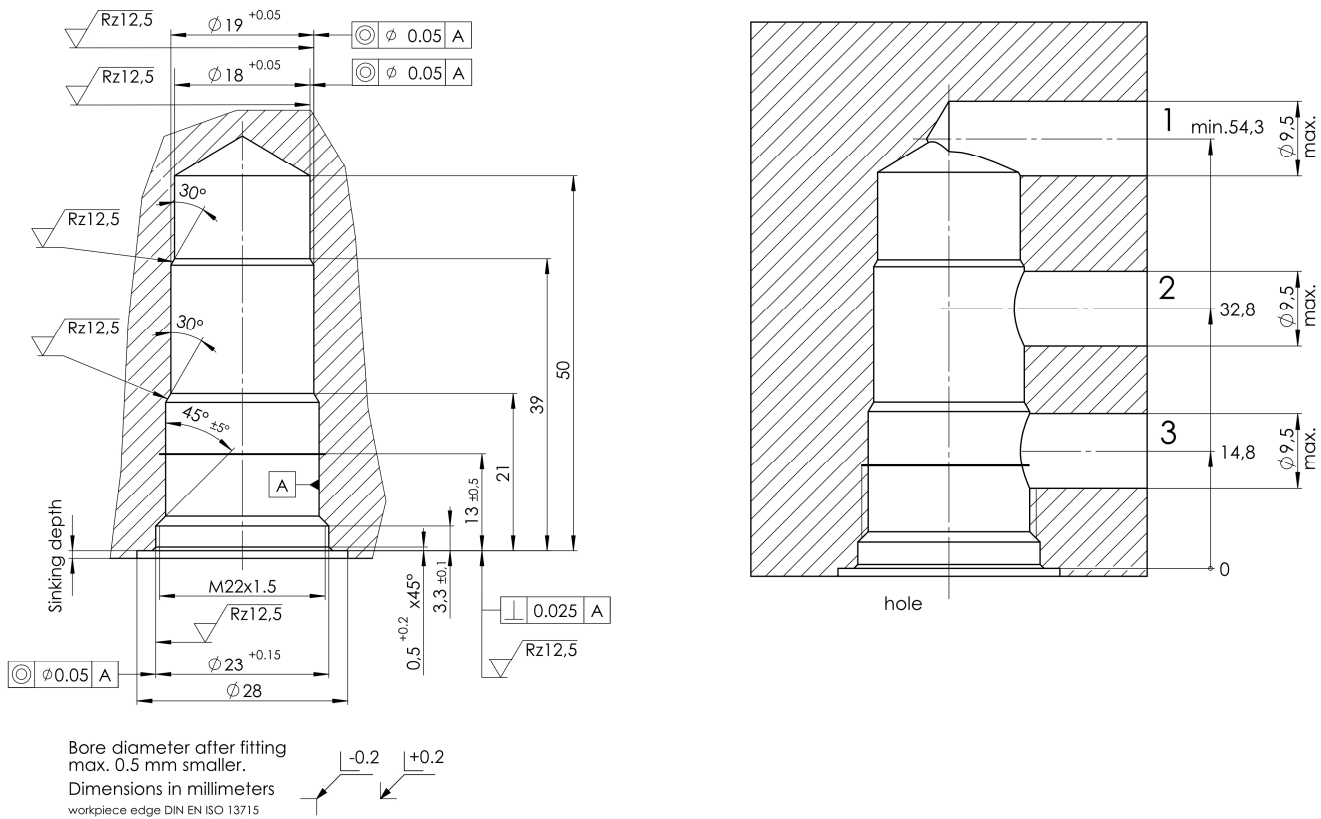

## 6 Installation

### General Information

- Observe all installation and safety information of the construction machine / attachment tools manufacturer.
- Only technically permitted changes are to be made on the construction machine.
- The user has to ensure that the device is suitable for the respective application.
- Application exclusively for the range of application specified by the manufacturer.
- Before installation or de-installation, the hydraulic system is to be depressurized.
- Settings are to be made by qualified personnel only.
- Opening is only to be performed with the approval of the manufacturer, otherwise the warranty is invalidated.

## 7 Notes, Standards and Safety Instructions

### General Instructions

- The views in drawings are shown in accordance with the European normal projection variant
- A comma ( , ) is used as a decimal point in drawings
- All dimensions are given in mm



### Standards

The following standards must be observed when installing and operating the valve:

- DIN EN ISO 13732-1:2008-12, Temperatures on accessible surfaces

## 8 Accessories